

男子団体戦

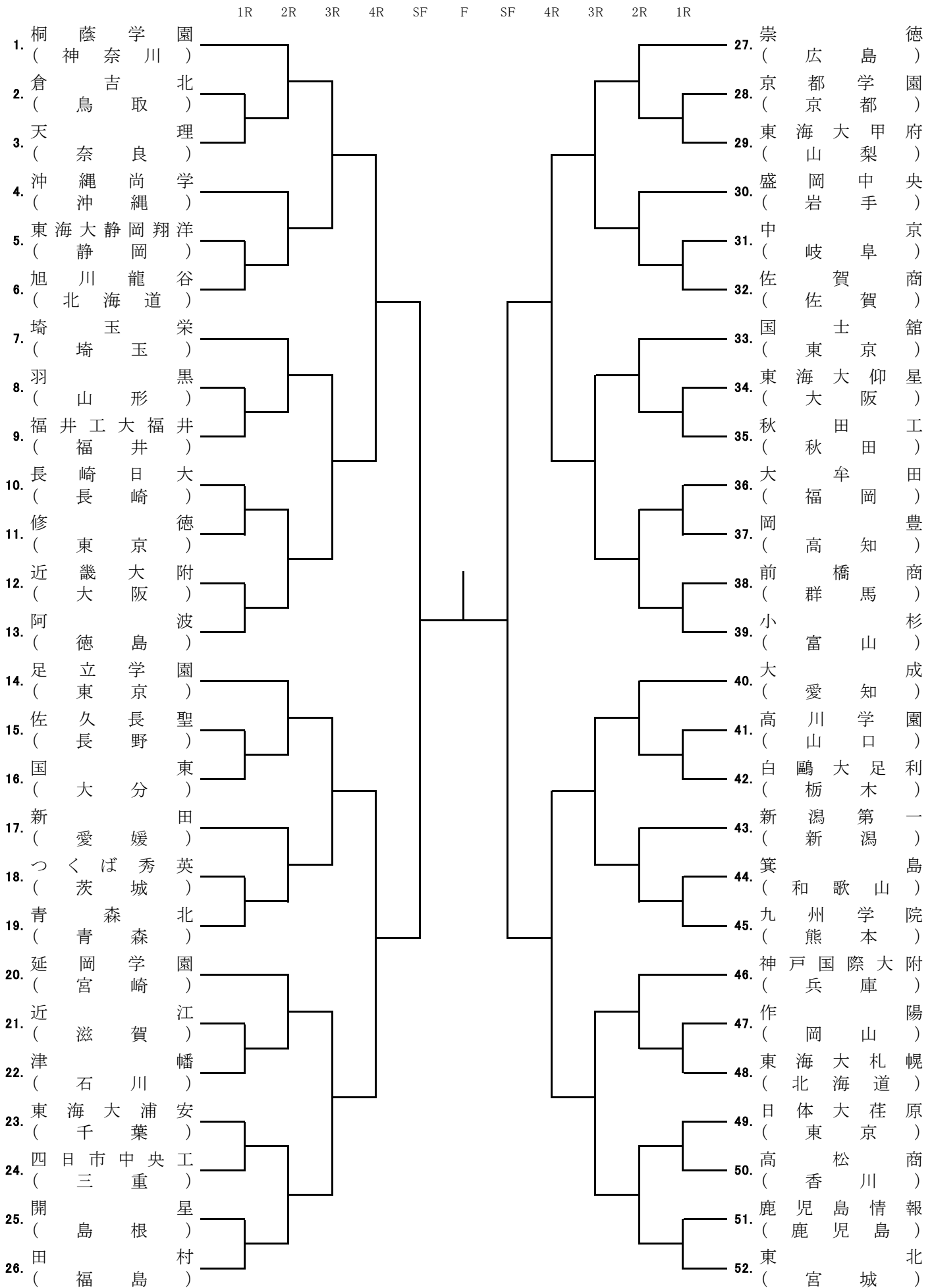

女子団体戦

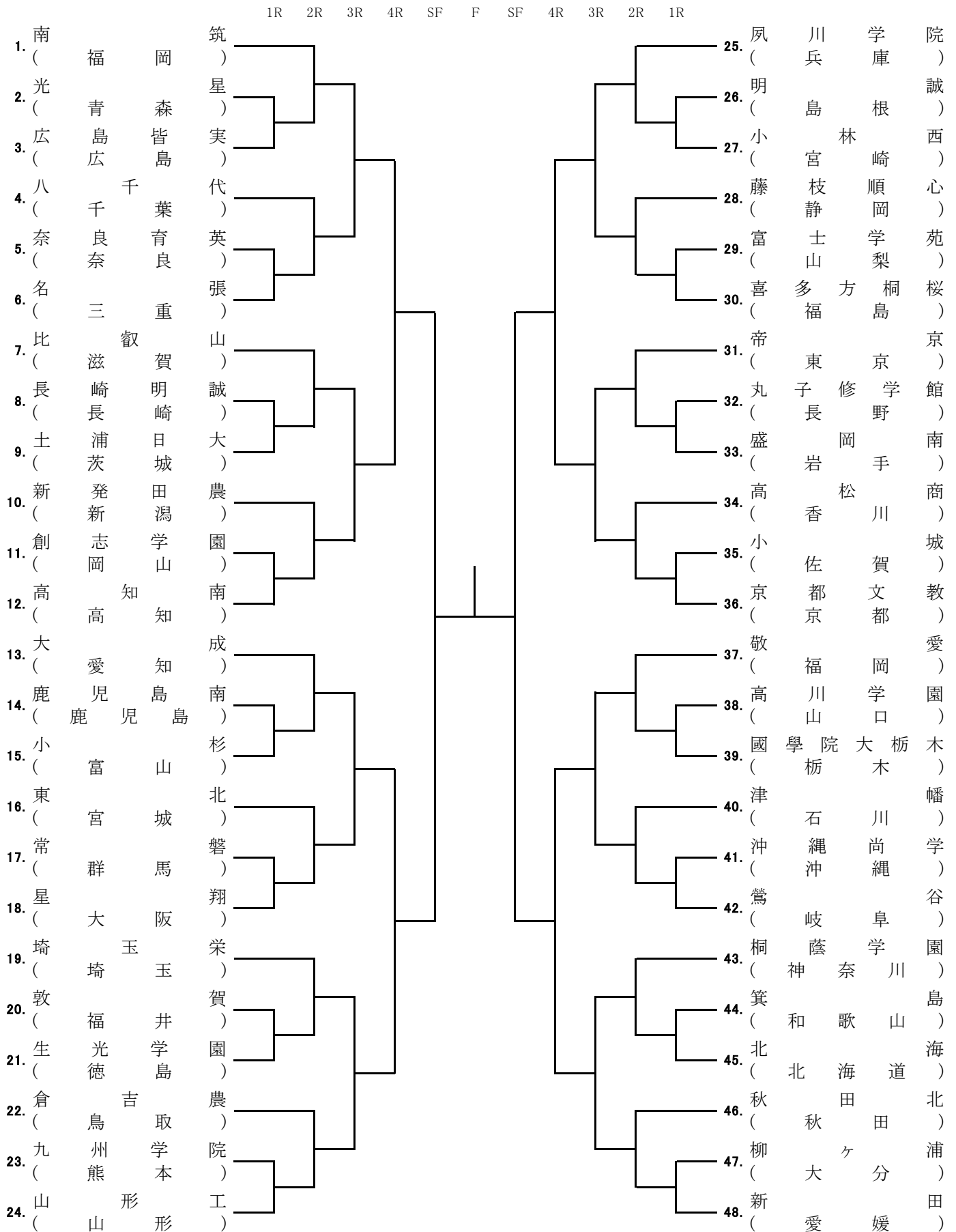

男子60kg級

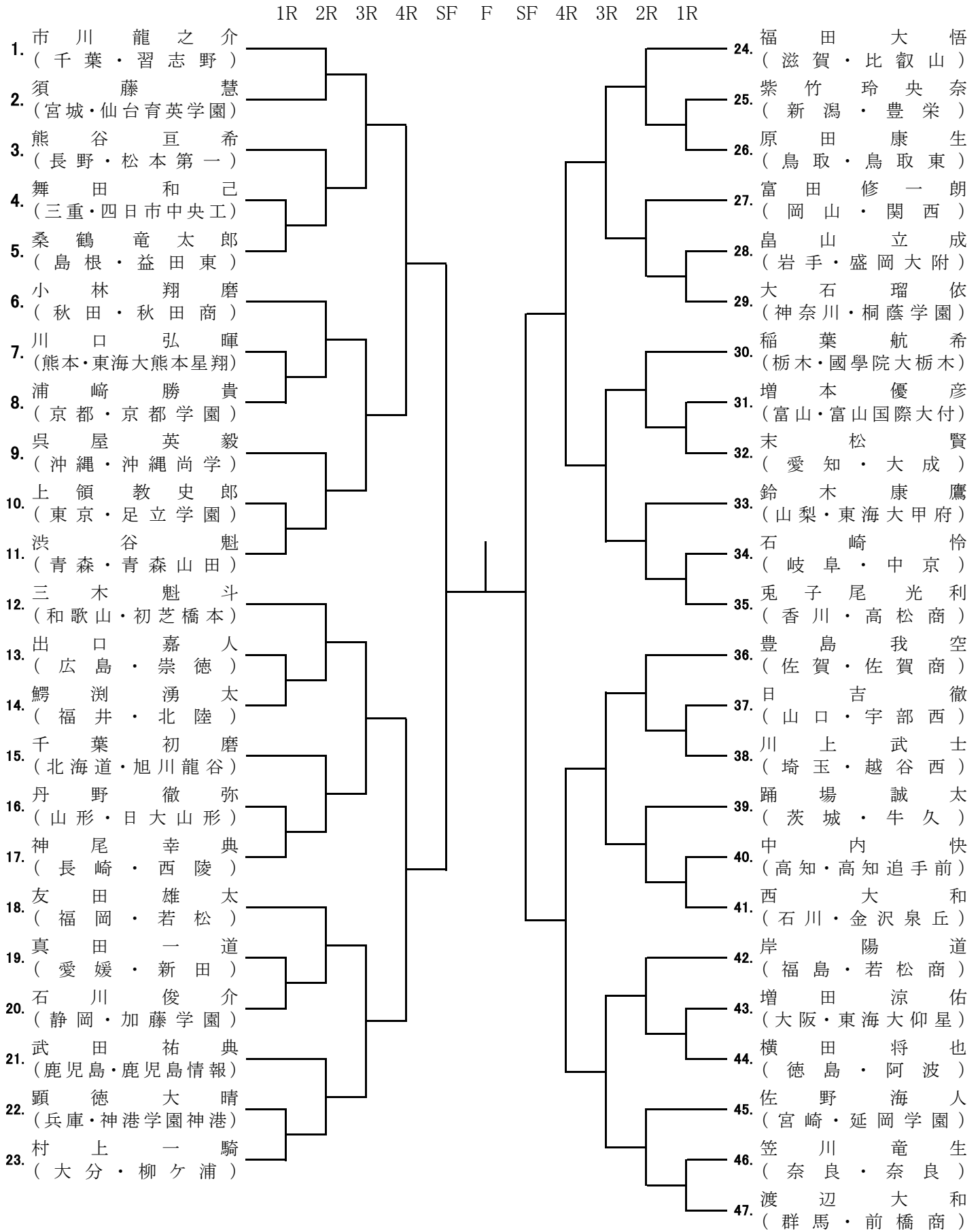

男子66kg級

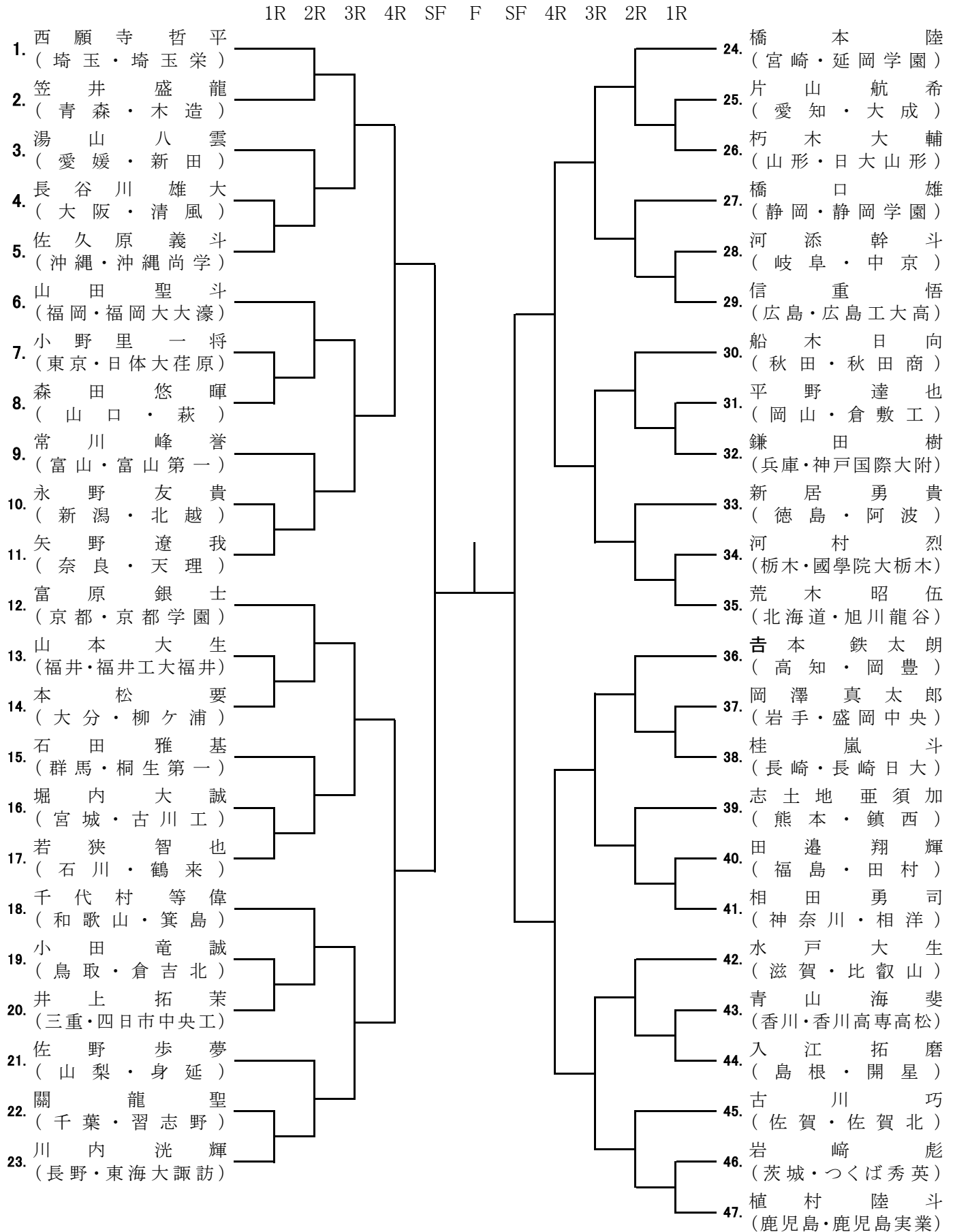

男子73kg級

1R 2R 3R 4R SF F SF 4R 3R 2R 1R

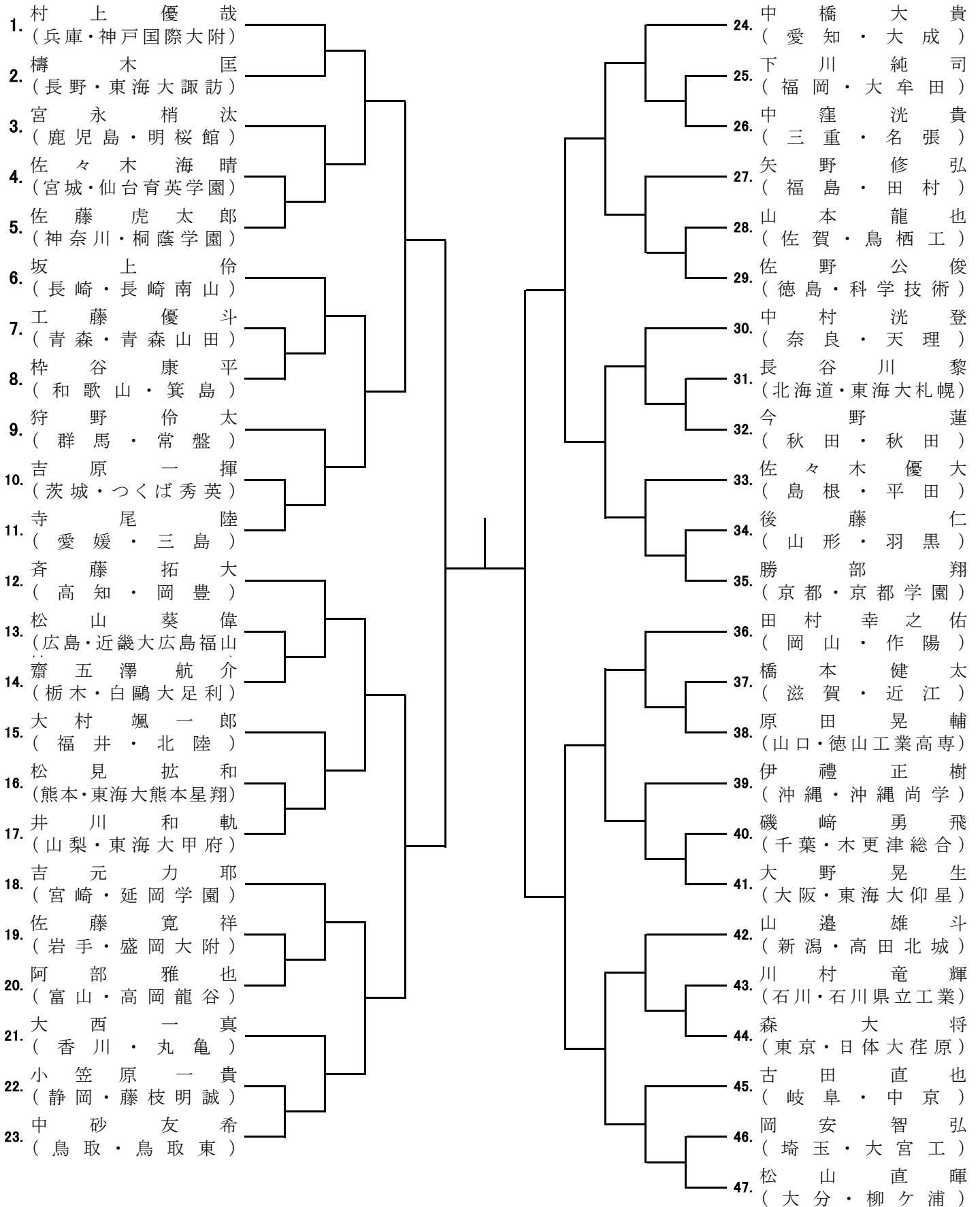

男子81kg級

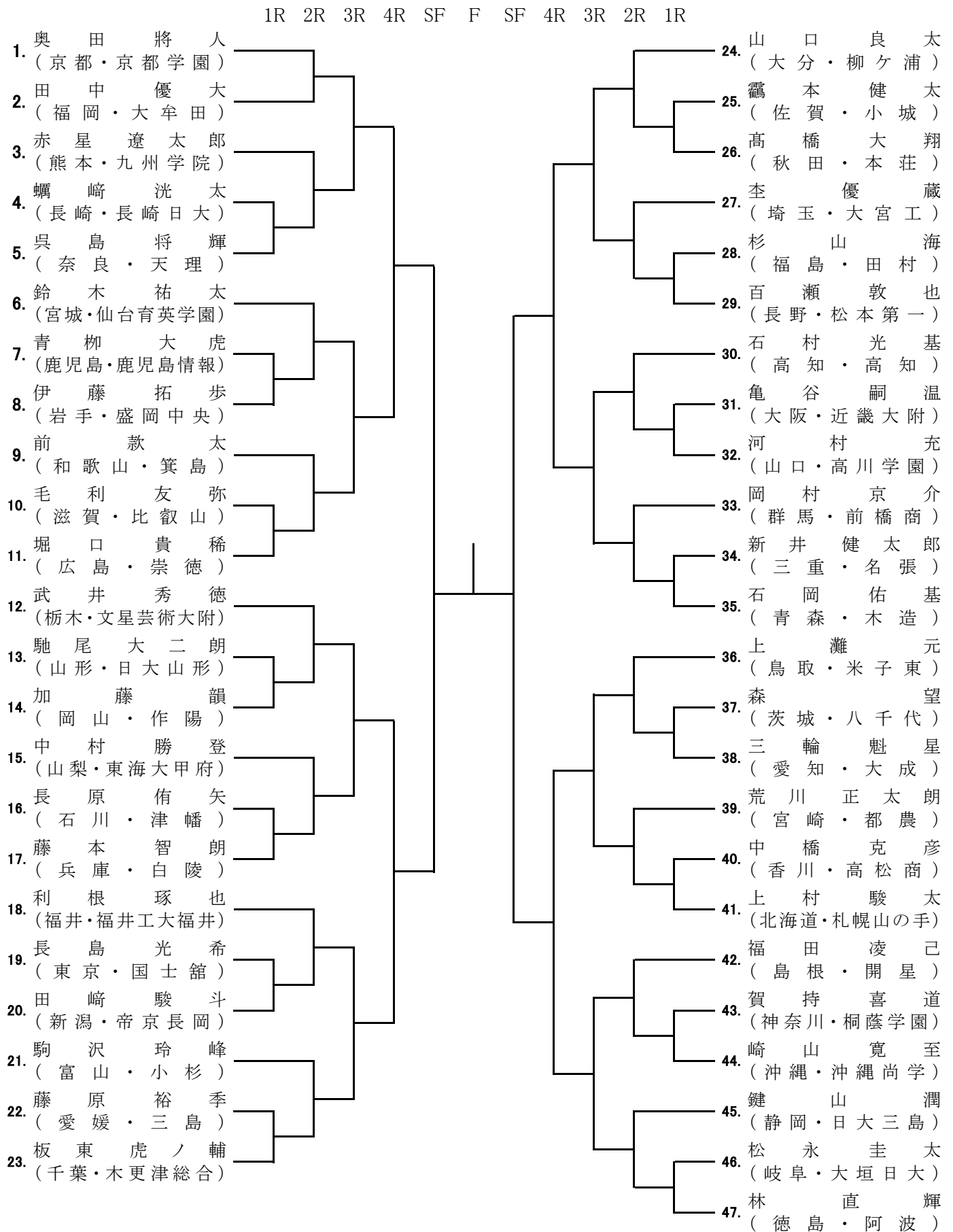

男子無差別

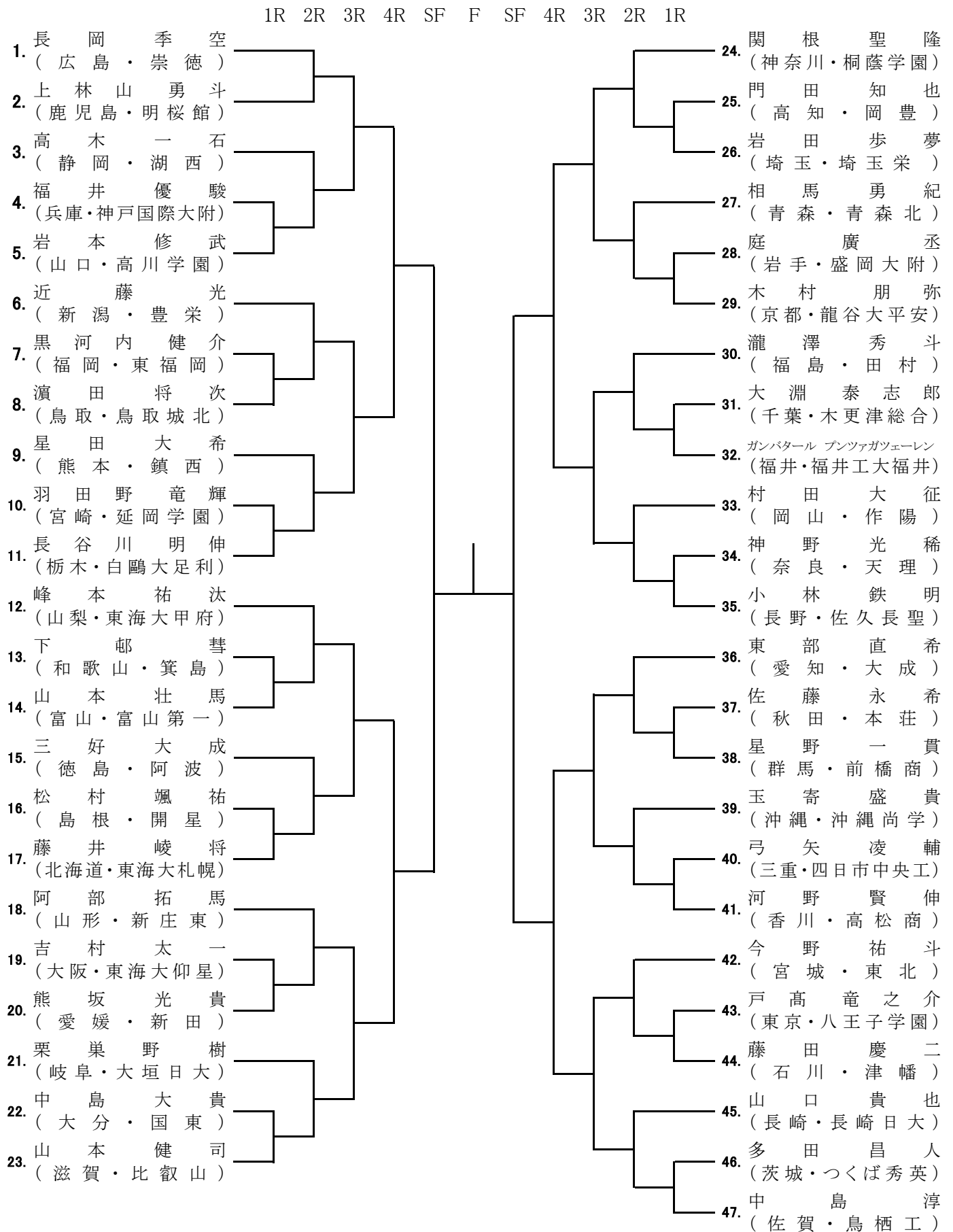

女子48kg級

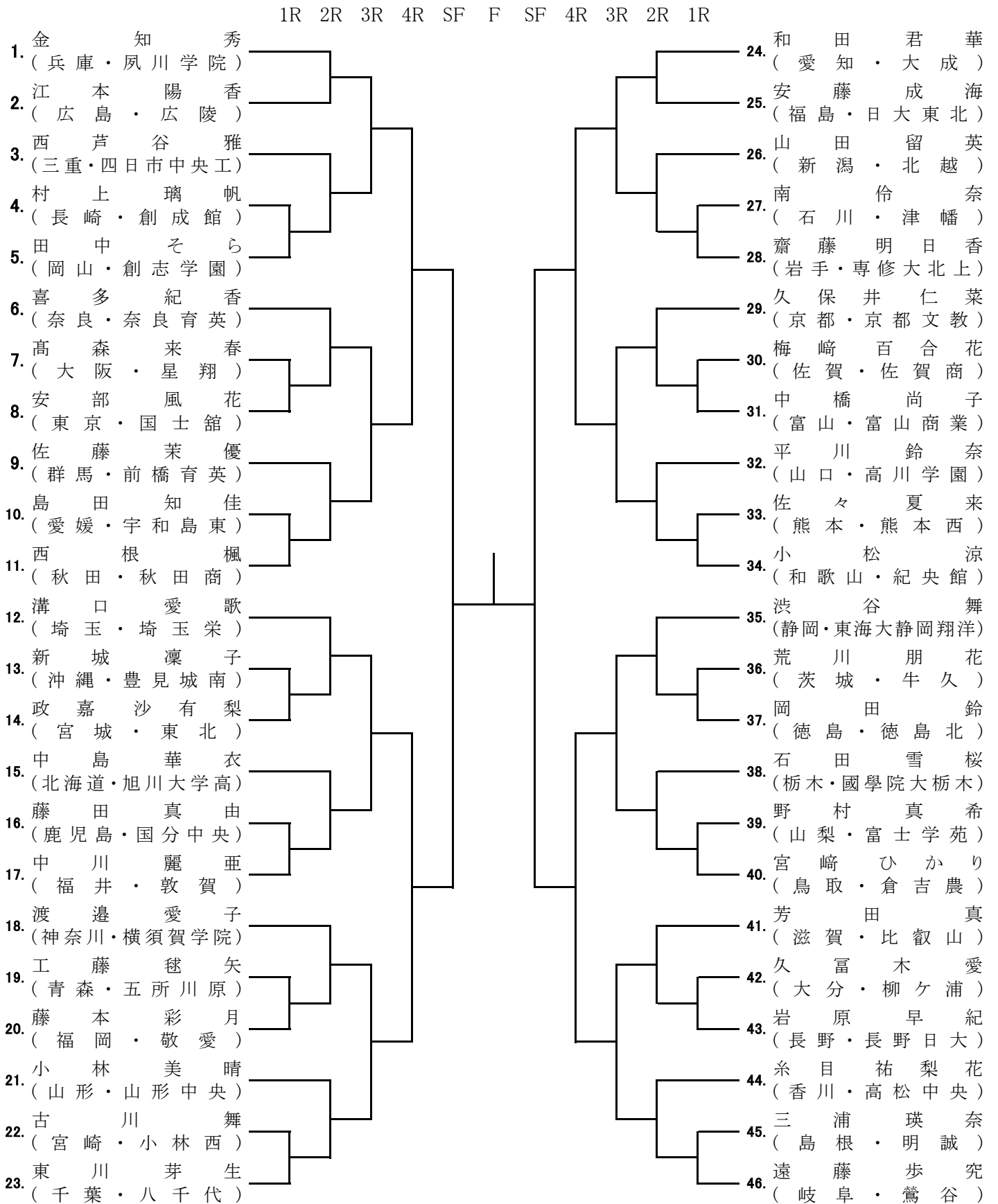

女子52kg級

1R 2R 3R 4R SF F SF 4R 3R 2R 1R

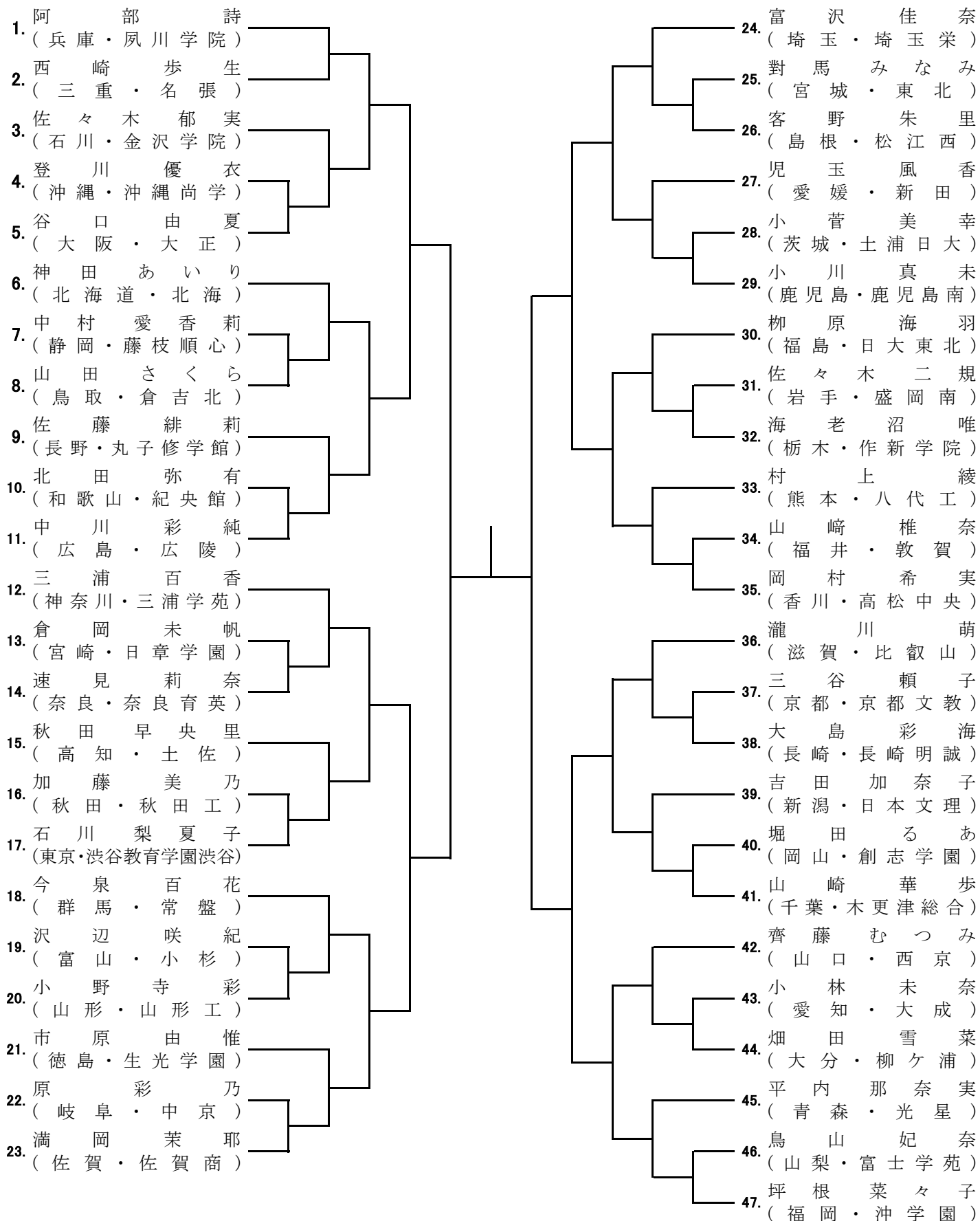

女子57kg級

1R 2R 3R 4R SF F SF 4R 3R 2R 1R

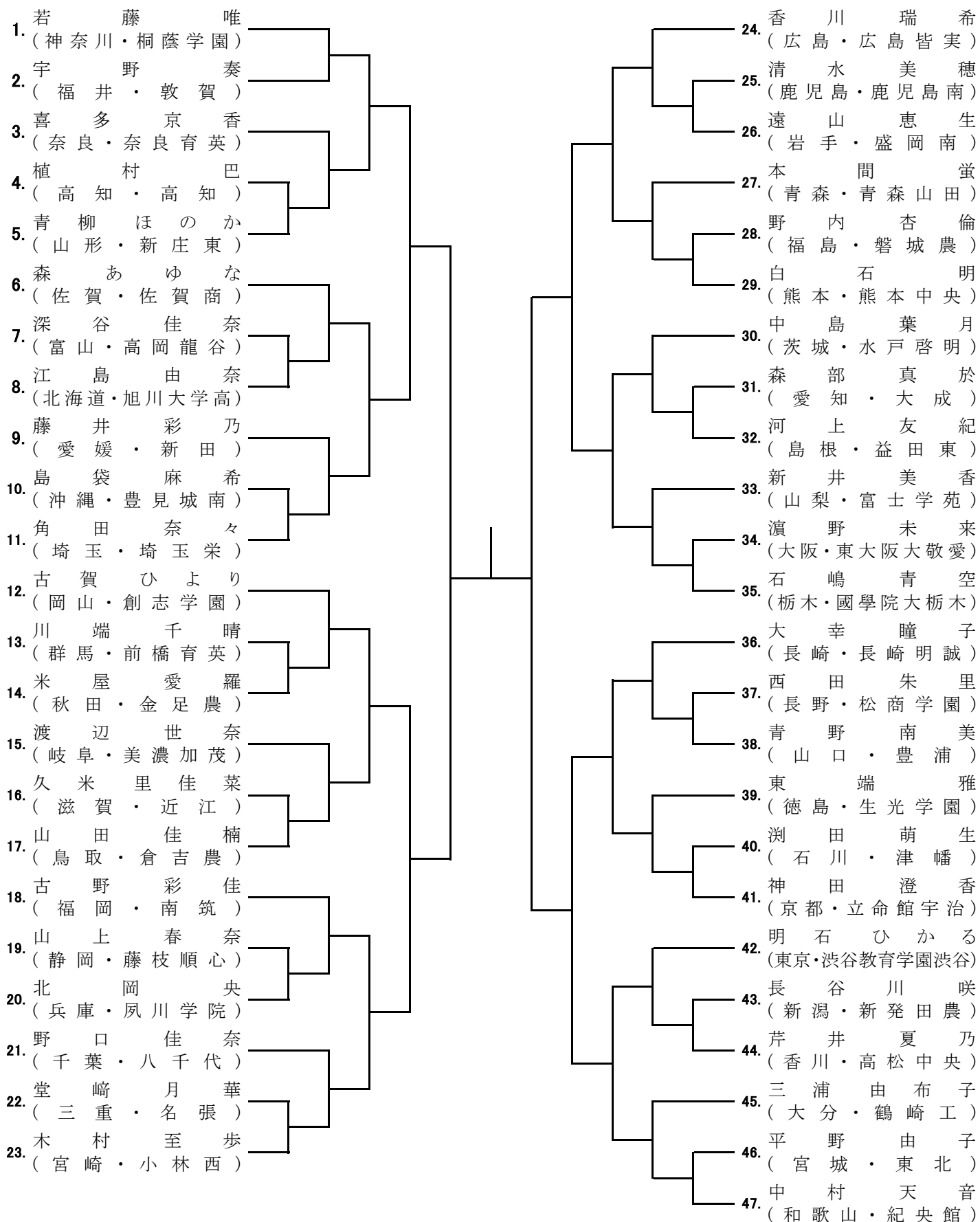

女子63kg級

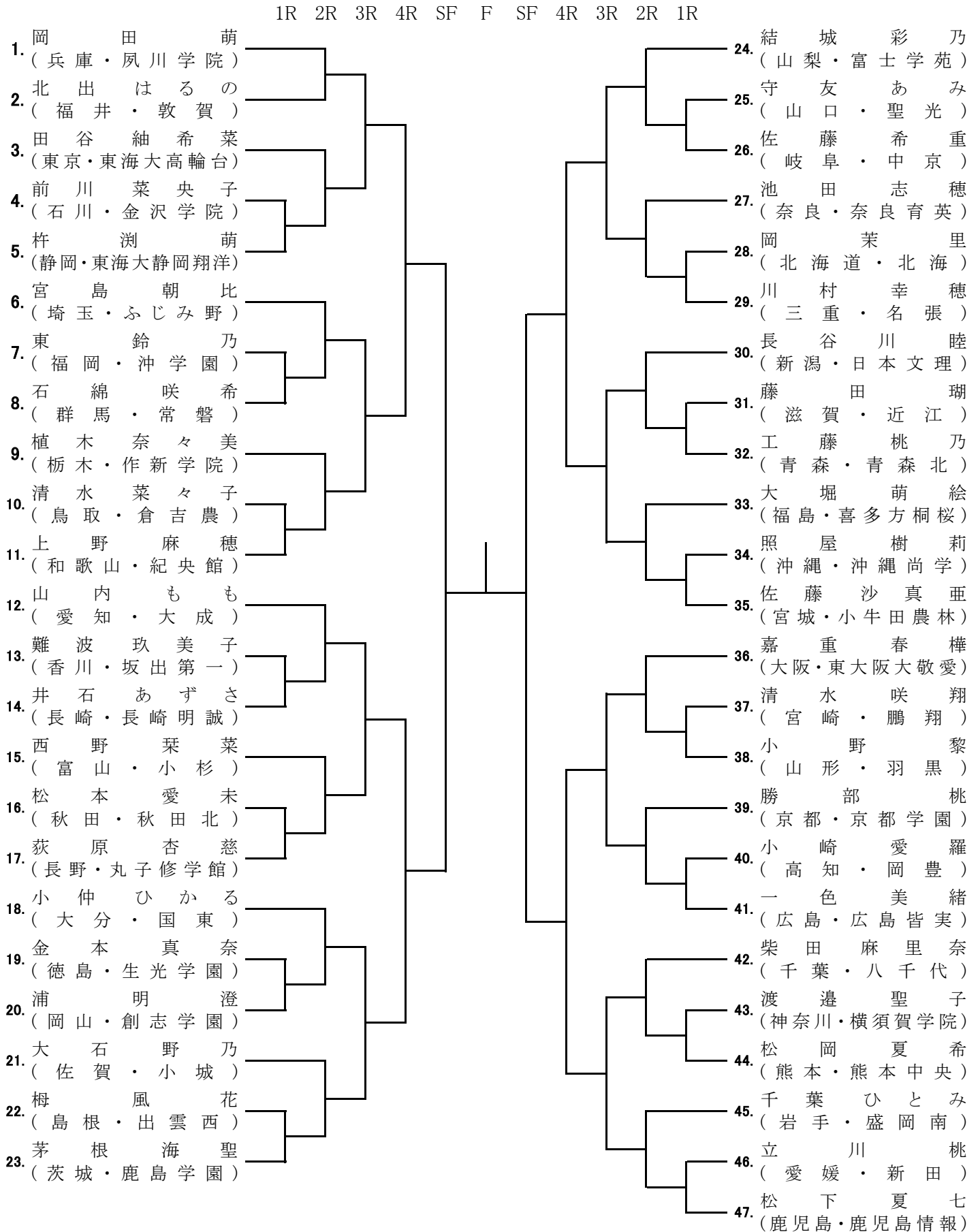

女子無差別

1R 2R 3R 4R SF F SF 4R 3R 2R 1R

